

Strainers

Den Holder is manufacturer of several types of strainers, screen and sieves which are designed in accordance with our clients requirements or any international standard.

Strainers

Den Holder is manufacturer of several types of strainers, screen and sieves which are designed in accordance with our clients requirements or any international standard. Strainers can be manufactured from pipe, fittings, plate or castings.

Standard designs are: T- and Y-type strainers, bucket-type strainers, conical strainers. Other designs can be engineered by us and

checked on strength and open area ratio to achieve lowest possible pressure loss. All strainers are manufactured with most accuracy to be perfect safeguards with minimum pressure loss.

Design, manufacturing and testing are covered by our ISO 9001 Quality System and all required documentation such as WPS/PQR and NDE-reports can be included.

ORDERING DATA

- DESIGN CODES** • ASME B31.3 / API / ANSI / BS / DIN / RtoD / PED / TÜV
- TYPE** • Y-type
- SIZE AND CLASS** • 1/2" – 24" / 150 – 2500 #
- MATERIALS**
- A105N / A350LF2 / A182-F5, F11, F22, F91 / C21
 - A106Gr.B / A333Gr.6 / A335Gr.P5, P11, P22, P91
 - A312-TP304(L), A312-TP316(L)/Ti, A312-TP321(L)
 - A182-F51 / 1.4462 / UNS S31803/S32750/S32760
 - Monel / Hastelloy C22, C50, C276 / Alloy 20/625/825
 - Titanium

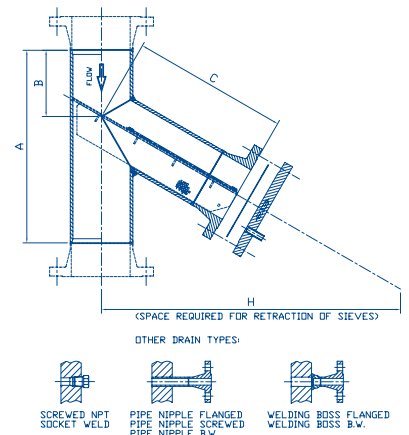
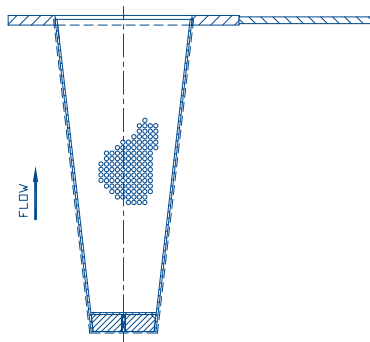
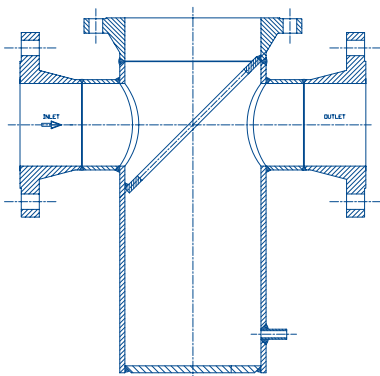

BUCKET TYPE STRAINERS

- LINE SIZE** • 2" thru 36"
- CLASS** • ANSI 150# thru 2500#
- SCHEDULE** • 10s thru XXS

CONICAL STRAINERS

- LINE SIZE** • 1" and above
- CLASS** • ANSI 150# thru 2500#
- or DIN PN 10 thru PN 250
- SCHEDULE** • 10s thru XXS

Y-TYPE STRAINERS

- LINE SIZE** • 1/2" thru 56"
- CLASS** • ANSI 150# thru 2500#
- SCHEDULE** • 10s thru XXS

EUROPE
Minervum 7238
4817 ZJ Breda
The Netherlands

Phone +31(0)88 11 67 600
Email: info@denholder.com



www.denholder.com

MIDDLE EAST
P.O. Box 3949
Abu Dhabi
United Arab Emirates
Phone +971 24 493 841
Fax +971 24 493 824
Email: info@denholder.ae